

HYMAX[®]

a **MUELLER** brand

HYMAX GRIP[®] COUPLING RESTRAINT (1.5" - 12") Product Specifications

FEATURES

- Joins and restrains a wide range of piping types and diameters
- Unique radial gripping system prevents pipe motion
- Universal gripping teeth fit metal and plastic pipes
- Ready to use, stab-fit design
- Allows 4° dynamic deflection per end, reducing future damage
- Durable ductile iron body
- Patented hydraulically-assisted gasket with 2-stage sealing

SPECIFICATIONS STANDARDS

- HYMAX GRIP meets or exceeds standards AWWA C219, NSF 61, NSF 372.

SIZE

- Available in nominal diameter from 1.5" - 12".

MATERIALS END RINGS

- 1.5" - 3": Cast steel ASTM A216 WCB.
- 4" - 12": Ductile iron casting ASTM A536 Grade 65-45-12.

CENTER RINGS

- 1.5" - 12" ductile iron casting ASTM A536 Grade 65-45-12.
- Product sizes 3" - 12" with handle.



GASKETS

- EPDM and NBR available. Both are compounded per ASTM D2000 for water and sewage, meet international standards for contact with drinking water.

GRIP CHAIN

Gripping teeth:

- Size 1.5" - 3": Fe₄Ni₀5Mo.
- Sizes 4" - 12": AISI 420.
- Sizes 4" - 12" High Pressure: Fe₄Ni₀5Mo.

BRIDGE

- Available in AISI 304 or 316 Stainless Steel.

SPHERICAL SPACERS

- Available in AISI 304 or 316 Stainless Steel.

COATING

- 100% fusion bonded epoxy for enhanced corrosion protection.
- Average thickness 14 mm.

NUTS, BOLTS & WASHERS

- Available in AISI 304 or 316 Stainless Steel. Rolled thread with anti-galling coating.



JOIN



REPAIR



RESTRAIN



TAP

MUELLER

PRODUCT PERFORMANCE

WORKING TEMPERATURE

- EPDM: -20° F up to +125° F
- NBR: -4° F up to +125° F

DYNAMIC DEFLECTION

- Up to 4° per side

MIN. PIPE INSERTION

- 3.6"

PRESSURES & ΔT

- ΔT - HDPE pipe expands and contracts with changes in temperature and exerts large pull-load forces on the coupling. ΔT for HDPE pipe is the change in temperature the coupling can withstand when installed on HDPE pipe.

MAXIMUM OFFSET FOR MISALIGNED PIPES

- 0.25"

MAXIMUM OUT OF ROUNDNESS

- 1.5" - 3": 0.12"
- 4" - 12": 0.16"

VACUUM TEST

- 12 psi

*Registered patent

Standard Pressure
GRIP

Steel, DI, CI, PVC & SS		HDPE	
ND (inch)	Working Pressure (psi)	Working Pressure (psi)	ΔT for HDPE SDR 9 (°F)
1.5/2	232	232	85
2.5	232	232	85
3	232	232	85
4	232	232	85
6	232	232	85
8	232	193	50
10	232	163	50
12	232	155	35

High Pressure GRIP

Steel, DI, CI, PVC, HDPE & SS		
ND (inch)	Working Pressure (psi)	ΔT for HDPE SDR 9 (°F)
4	250	100
6	250	100
8	250	100
10	250	100
12	250	70

PRODUCT TABLES

TORQUE

ND (inch)	EPDM (ft-lb)	NBR (ft-lb)
1.5/2	50	50
2.5	50	50
3	50	50
4	90	105
6	110	110
8	200	200
10	200	200
12	200	200

PRODUCT CONFIGURATIONS

The product is offered in several different configurations. Note that the "xx" marking in the Cat. no. should be replaced as directed: Part Number 890-XX

56 - Standard Pressure Grip with EPDM gasket, Fasteners AISI 304SS

57 - Standard Pressure Grip with NBR gasket, Fasteners AISI 304SS

58 - High Pressure Grip with EPDM gasket, Fasteners AISI 304SS

59 - High Pressure Grip with NBR gasket, Fasteners AISI 304SS

96 - Standard Pressure Grip with EPDM gasket, Fasteners AISI 316SS

For example -

890-XX-015039-16 should be read as 890-56-015039-16 for EPDM gasket and 890-57-015039-16 for NBR gasket.

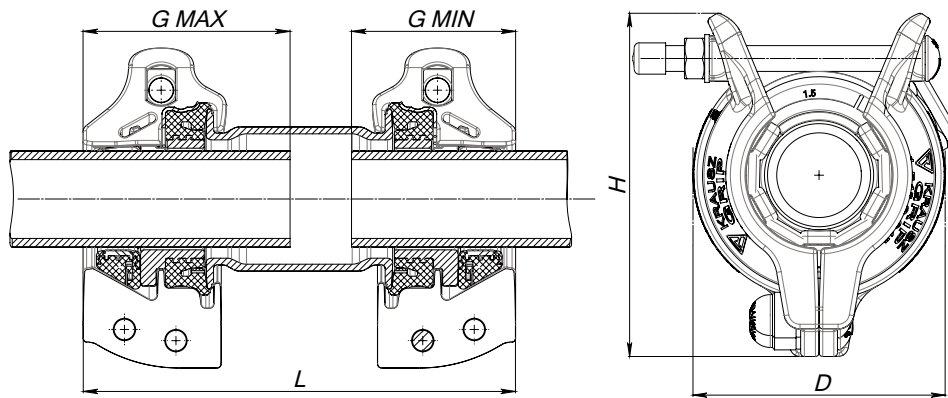

HYMAX GRIP NOMINAL SIZE 1.5" - 3" (*)

HYMAX Part Number	Nominal Diameter (inch)	Overall Range (inch)	Before Removal of the Inner Layer (inch)	After Removal of the Inner Layer (inch)	L (inch)	D (inch)	H (inch)	Bolts Qty. - Size	G - Max Stab Depth (inch)	Approx. Weight (lbs)
890-XX-015039-16	1.5/2	1.54 - 2.64	1.54 - 2.20	2.17 - 2.64	10	5.35	7.48	2 - M14	4.5	15.45
890-XX-025059-16	2.5	2.32 - 3.43	2.32 - 2.99	2.95 - 3.43	10	6.18	8.07	2 - M14	4.5	20.26
890-XX-030080-16	3	3.15 - 4.17	3.15 - 3.74	3.70 - 4.17	11.93	6.93	9.06	2 - M14	5.5	25.53

* NOTE: configs 58 & 59 are not relevant for 1.5" - 3" sizes

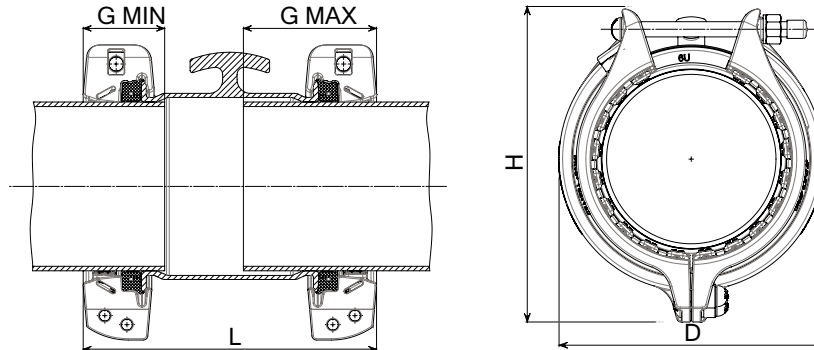

HYMAX GRIP NOMINAL SIZE 4" - 12"

HYMAX Part Number	Nominal Diameter (inch)	Overall Range (inch)	L (inch)	D (inch)	H (inch)	G - Max Stab Depth (inch)	Bolts Qty. - Size	Approx. Weight (lbs)
890-XX-04111-16	4	4.40 - 5.10	11.4	8.7	10.6	5.3	2 - 5/8	32
890-XX-06165-16	6	6.50 - 7.20	12.8	10.9	12.9	5.9	2 - 5/8	43
890-XX-08216-16	8	8.50 - 9.40	13.3	13.8	15.7	6.1	2 - 3/4	74
890-XX-10270-16	10	10.65 - 11.55	13.5	16.2	18.2	6.3	2 - 3/4	92
890-XX-12322-16	12	12.68 - 13.39	13.5	17.4	19.8	6.3	2 - 3/4	100

To learn more, visit HymaxUSA.com.

Mueller refers to one or more of Mueller Water Products, Inc., a Delaware corporation ("MWP"), and its subsidiaries. MWP and each of its subsidiaries are legally separate and independent entities when providing products and services. MWP does not provide products or services to third parties. MWP and each of its subsidiaries are liable only for their own acts and omissions and not those of each other. MWP brands include Mueller®, Echologics®, Hydro Gate®, Hydro-Guard®, HYMAX®, Krausz®, Jones®, Mi.Net®, Milliken®, Pratt®, Pratt Industrial®, Singer®, and U.S. Pipe Valve & Hydrant. Please see muellerwp.com/brands to learn more.

© 2021 Mueller Co., LLC. All Rights Reserved. The trademarks, logos and service marks displayed in this document are the property of Mueller Co., LLC, its affiliates or other third parties. Products above marked with a section symbol (§) are subject to patents or patent applications. For details, visit www.mwppat.com. These products are intended for use in potable water applications. Please contact your Mueller Sales or Customer Service Representative concerning any other application(s).

F 14512 PS0003 6/21

