

HYMAX[®]

a **MUELLER** brand

HYMAX[®] FLANGE ADAPTOR* AND HYMAX LONG BODY FLANGE ADAPTOR (14" - 60")

Product Specifications

FEATURES

- Using the game-changing HYMAX technology proven in over 1M installations in the US
- Suitable for all types of pipes - ductile iron, cast iron, steel, copper, PE, PVC, AC, GRP
- Patented hydraulically-assisted gasket with 2-stage sealing
- Lightweight construction enables fast and easy installation
- Allows 4° dynamic deflection on each end, reducing future damage

SPECIFICATIONS STANDARDS

- HYMAX flange adaptor and long body flange adaptor meet or exceed requirements of standards: NSF 61 and NSF 372.

SIZE

- Available in nominal diameter from 14" - 24" standard.
- 26" - 60" MTO (made to order). Call Mueller for details.

MATERIALS

FLANGE BODY

- 14" - 60" ASTM A283/A283M Grade C steel

FLANGE

- 14" - 24" meets AWWA class D.
- 26" - 60" Call Mueller for details.

*Registered patent



JOIN



REPAIR



RESTRAIN



TAP



END RINGS

- 14" - 16" ASTM A283/A283M Grade C steel (or ductile iron casting ASTM A536 Grade 65-45-12).
- 18" - 60" ASTM A283/A283M Grade C steel.

SPHERICAL SPACERS

- AISI 304 stainless steel.

GASKETS

- EPDM and NBR available. Both are compounded for water and sewage, meet international standards for contact with drinking water.

BRIDGE

- AISI 304 stainless steel.

COATING

- 100% fusion bonded epoxy for enhanced corrosion protection.
- Nominal thickness 14 mm.

NUTS AND BOLTS

- AISI 304 stainless steel. Rolled thread and anti-galling coating.

MUELLER

PRODUCT PERFORMANCE (*)

WORKING TEMPERATURE

- EPDM: -20° F up to +125° F
- NBR: -4° F up to +125° F

DYNAMIC DEFLECTION

- Up to 4°

MIN. PIPE INSERTION

- 14" - 60": 4"

MAXIMUM OFFSET FOR MISALIGNED PIPES

- 14" - 60": 0.24"

MAXIMUM OUT OF ROUNDNESS

- 14" - 60": 0.51"

WORKING PRESSURE

- 14" - 24": 175 psi
- 26" - 60": Call Mueller for details.

VACUUM TEST

- 12 psi

PRODUCT TABLES

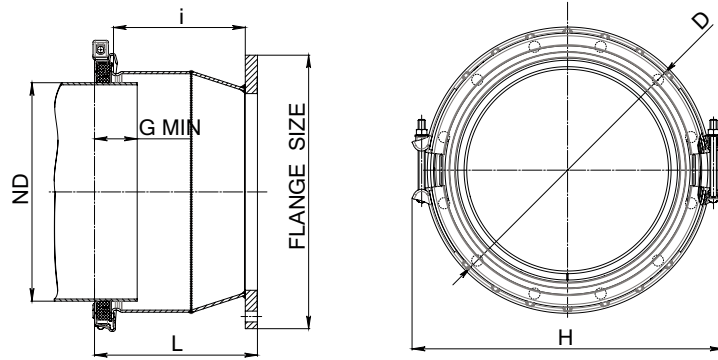

HYMAX FLANGE ADAPTOR NOMINAL SIZE 14" - 24"

HYMAX Part Number	ND (mm)	Flange (inch)	Overall Range (inch)	Before Removal of the Inner Layer (inch)	After Removal of the Inner Layer (inch)	D1 (inch)	H (inch)	i (inch)	L (inch)	D2 (inch)	B (inch)	Bolts Qty. and Size	Torque (ft-lb)	Approx. Weight (lbs)
874-56-14037812	14	14	15.00 - 17.10	15.00 - 16.10	16.02 - 17.10	021.0	23.2	12.05	15.1	021.0	015.43	2 - M16	150	115
874-56-16043412	16	16	17.10 - 19.20	17.10 - 18.19	18.11 - 19.20	023.2	25.6	12.05	15.1	023.5	017.91	2 - M16	150	125
874-56-18048812	18	18	19.20 - 21.30	19.20 - 20.29	20.21 - 21.30	025.3	27.8	12.05	15.1	025.0	019.09	2 - M16	150	135
874-56-20054012	20	20	21.25 - 23.35	21.25 - 22.35	22.27 - 23.35	027.3	29.8	12.05	15.2	027.5	021.34	2 - M16	150	155
874-56-24060612	24	24	23.85 - 25.95	23.85 - 24.96	24.88 - 25.95	029.1	31.7	12.05	15.4	032.0	025.91	2 - M16	150	184
874-56-24062412	24	24	24.60 - 26.70	24.60 - 25.67	25.59 - 26.70	030.6	33.2	12.05	15.4	032.0	025.91	2 - M16	150	187

HYMAX FLANGE ADAPTOR NOMINAL SIZE 26" - 60"

26" - 60" - MTO (made to order) is available

HYMAX FLANGE ADAPTOR LONG BODY NOMINAL SIZE 14" - 24"

HYMAX Part Number	ND (mm)	Flange (inch)	Overall Range (inch)	Before Removal of the Inner Layer (inch)	After Removal of the Inner Layer (inch)	D1 (inch)	H (inch)	i (inch)	L (inch)	D2 (inch)	B (inch)	Bolts Qty. and Size	Torque (ft-lb)	Approx. Weight (lbs)
974-56-14037812	14	14	15.00 - 17.10	15.00 - 16.10	16.02 - 17.10	021.0	23.2	15.8	18.7	021.0	015.43	2 - M16	150	117
974-56-16043412	16	16	17.10 - 19.20	17.10 - 18.19	18.11 - 19.20	023.2	25.6	15.8	18.7	023.5	017.91	2 - M16	150	133
974-56-18048812	18	18	19.20 - 21.30	19.20 - 20.29	20.21 - 21.30	025.3	27.8	15.8	18.7	025.0	019.09	2 - M16	150	142
974-56-20054012	20	20	21.25 - 23.35	21.25 - 22.35	22.27 - 23.35	027.3	29.8	15.8	18.8	027.5	021.34	2 - M16	150	151
974-56-24060612	24	24	23.85 - 25.95	23.85 - 24.96	24.88 - 25.95	029.1	31.7	15.8	18.9	032.0	025.91	2 - M16	150	168
974-56-24062412	24	24	24.60 - 26.70	24.60 - 25.67	25.59 - 26.70	030.6	33.2	15.8	18.9	032.0	025.91	2 - M16	150	173

HYMAX FLANGE ADAPTOR LONG BODY NOMINAL SIZE 26" - 60"

26" - 60" - MTO (made to order) is available

To learn more, visit HymaxUSA.com.

Mueller refers to one or more of Mueller Water Products, Inc., a Delaware corporation ("MWP"), and its subsidiaries. MWP and each of its subsidiaries are legally separate and independent entities when providing products and services. MWP does not provide products or services to third parties. MWP and each of its subsidiaries are liable only for their own acts and omissions and not those of each other. MWP brands include Mueller®, Echologics®, Hydro Gate®, Hydro-Guard®, HYMAX®, Krausz®, Jones®, Mi.Net®, Milliken®, Pratt®, Pratt Industrial®, Singer®, and U.S. Pipe Valve & Hydrant. Please see muellerwp.com/brands to learn more.

© 2021 Mueller Co., LLC. All Rights Reserved. The trademarks, logos and service marks displayed in this document are the property of Mueller Co., LLC., its affiliates or other third parties. Products above marked with a section symbol (§) are subject to patents or patent applications. For details, visit www.mwppat.com. These products are intended for use in potable water applications. Please contact your Mueller Sales or Customer Service Representative concerning any other application(s).

F 14539 PS0007 8/21

