



# HYMAX<sup>®</sup> FLANGE ADAPTOR\* AND HYMAX LONG BODY FLANGE ADAPTOR (14"-60")

**HYMAX<sup>®</sup>**  
Repair the past. Connect the future.

## PRODUCT SPECIFICATIONS

### FEATURES

- USING THE GAME-CHANGING HYMAX TECHNOLOGY, PROVEN IN OVER 1M INSTALLATIONS IN THE US
- SUITABLE FOR ALL TYPES OF PIPES - DUCTILE IRON, CAST IRON, STEEL, COPPER, PE, PVC, AC, GRP
- PATENTED HYDRAULICALLY-ASSISTED GASKET WITH 2-STAGE SEALING
- LIGHTWEIGHT CONSTRUCTION ENABLES FAST AND EASY INSTALLATION
- ALLOWS 4° DYNAMIC DEFLECTION, REDUCING FUTURE PIPE DAMAGE

### SPECIFICATIONS

#### STANDARDS

HYMAX FLANGE ADAPTOR AND LONG BODY FLANGE ADAPTOR MEET OR EXCEED REQUIREMENTS OF STANDARDS: NSF-61 AND NSF-372.

#### SIZE/LENGTH

AVAILABLE IN NOMINAL DIAMETER FROM 14"-24" STANDARD. 26"-60" MTO (MADE TO ORDER). CONTACT KRAUSZ FOR DETAILS.

#### MATERIALS

##### FLANGED BODY

14"-60" ASTM A283 / A283M GRADE C STEEL.

##### FLANGE

14"-24" MEETS AWWA CLASS D.  
26"-60" CONTACT KRAUSZ FOR DETAILS.

##### END RINGS

14"-16" ASTM A283 / A283M GRADE C STEEL.  
(OR DUCTILE IRON CASTING ASTM A536 GRADE 60-40-18).  
18"-60" ASTM A283 / A283M GRADE C STEEL.

##### SPHERICAL SPACERS

AISI 304 STAINLESS STEEL.

##### GASKET

EPDM AND NBR AVAILABLE. BOTH ARE COMPOUNDED FOR WATER AND SEWAGE, MEET INTERNATIONAL STANDARDS FOR CONTACT WITH DRINKING WATER.

##### BRIDGE

AISI 304 STAINLESS STEEL.

##### COATING

100% FUSION BONDED EPOXY FOR ENHANCED CORROSION PROTECTION. NOMINAL THICKNESS 14 MIL.

##### NUTS AND BOLTS

AISI 304 STAINLESS STEEL. ROLLED THREAD AND ANTI-GALLING COATING.

## PRODUCT PERFORMANCE (\*)

<b>WORKING TEMPERATURE</b>	EPDM: -20°F UP TO +125°F NBR: -4°F UP TO +125°F
<b>DYNAMIC DEFLECTION</b>	UP TO 4°
<b>MIN. PIPE INSERTION</b>	14" - 60" 4"
<b>MAXIMUM OFFSET FOR MISALIGNED PIPES</b>	14" - 60" 0.24"
<b>MAXIMUM OUT OF ROUNDNESS</b>	14" - 60" 0.51"
<b>WORKING PRESSURE</b>	14" - 24": 175 PSI (26" - 60": CONTACT KRAUSZ FOR DETAILS)
<b>RATED PRESSURE</b>	14" - 24": 262 PSI (26" - 60": CONTACT KRAUSZ FOR DETAILS)
<b>VACUUM TEST</b>	12 PSI

## PRODUCT TABLES

### HYMAX FLANGE ADAPTOR NOMINAL SIZE 14"-24"

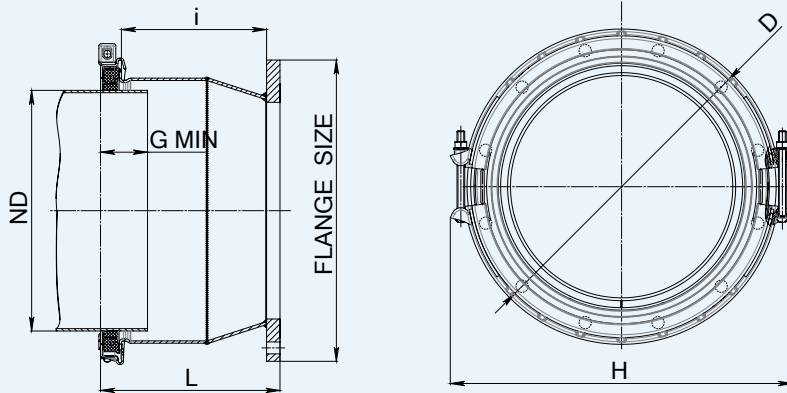

Krausz Part Number	ND (mm)	Flange (inch)	Overall Range (inch)	Before removal of inner layer (inch)	After removal of inner layer	D1 (inch)	H (inch)	i (inch)	L (inch)	D2 (inch)	B (inch)	Bolts Qty. -Size	Torque (Ft-Lbs)	Approx. Weight (Lbs)
874-56-14037812	14	14	15.00-17.10	15.00-16.10	16.02-17.10	Ø21.0	23.2	12.05	15.1	Ø21.0	Ø15.43	2 -M16	150	115
874-56-16043412	16	16	17.10-19.20	17.10-18.19	18.11-19.20	Ø23.2	25.6	12.05	15.1	Ø23.5	Ø17.91	2 -M16	150	125
874-56-18048812	18	18	19.20-21.30	19.20-20.29	20.21-21.30	Ø25.3	27.8	12.05	15.1	Ø25.0	Ø19.09	2 -M16	150	135
874-56-20054012	20	20	21.25-23.35	21.25-22.35	22.27-23.35	Ø27.3	29.8	12.05	15.2	Ø27.5	Ø21.34	2 -M16	150	155
874-56-24060612	24	24	23.85-25.95	23.85-24.96	24.88-25.95	Ø29.1	31.7	12.05	15.4	Ø32.0	Ø25.91	2 -M16	150	184
874-56-24062412	24	24	24.60-26.70	24.60-25.67	25.59-26.70	Ø30.6	33.2	12.05	15.4	Ø32.0	Ø25.91	2 -M16	150	187

### HYMAX FLANGE ADAPTOR NOMINAL SIZE 26"-60"

26"-60" - MTO (MADE TO ORDER) IS AVAILABLE

### HYMAX FLANGE ADAPTOR LONG BODY NOMINAL SIZE 14"-24"

Krausz Part Number	ND (mm)	Flange (inch)	Overall Range (inch)	Before Removal of Inner Layer (inch)	After Removal of Inner Layer	D1 (inch)	H (inch)	i (inch)	L (inch)	D2 (inch)	B (inch)	Bolts Qty. -Size	Torque (Ft-Lbs)	Approx. Weight (Lbs)
974-56-14037812	14	14	15.00-17.10	15.00-16.10	16.02-17.10	Ø21.0	23.2	15.8	18.7	Ø21.0	Ø15.43	2 -M16	150	117
974-56-16043412	16	16	17.10-19.20	17.10-18.19	18.11-19.20	Ø23.2	25.6	15.8	18.7	Ø23.5	Ø17.91	2 -M16	150	133
974-56-18048812	18	18	19.20-21.30	19.20-20.29	20.21-21.30	Ø25.3	27.8	15.8	18.7	Ø25.0	Ø19.09	2 -M16	150	142
974-56-20054012	20	20	21.25-23.35	21.25-22.35	22.27-23.35	Ø27.3	29.8	15.8	18.8	Ø27.5	Ø21.34	2 -M16	150	151
974-56-24060612	24	24	23.85-25.95	23.85-24.96	24.88-25.95	Ø29.1	31.7	15.8	18.9	Ø32.0	Ø25.91	2 -M16	150	168
974-56-24062412	24	24	24.60-26.70	24.60-25.67	25.59-26.70	Ø30.6	33.2	15.8	18.9	Ø32.0	Ø25.91	2 -M16	150	173

### HYMAX FLANGE ADAPTOR LONG BODY NOMINAL SIZE 26"-60"

26"-60" - MTO (MADE TO ORDER) IS AVAILABLE

# **HYMAX**®

Repair the past. Connect the future.

---

 **KRAUSZ** is the creator of HYMAX

**331 SW 57TH AVENUE, OCALA, FLORIDA 34474**

**TEL: 855-457-2879 | 855-4KRAUSZ**

**FAX: 352-304-5787**

**[info@krauszusa.com](mailto:info@krauszusa.com) | [www.krauszusa.com](http://www.krauszusa.com)**

---

This product is protected under a registered patent. See Krausz USA website for details. Copyright © 2017 Krausz Industries Ltd., All rights reserved