



HYMAX[®] CATHODIC*

(14"-60")

HYMAX[®]
Repair the past. Connect the future.

PRODUCT SPECIFICATIONS

FEATURES

- HYMAX COUPLING WITH CATHODIC PROTECTION
- USING GAME-CHANGING HYMAX TECHNOLOGY, PROVEN IN OVER 1M INSTALLATIONS IN THE US
- SUITABLE FOR ALL METAL PIPES
- PATENTED HYDRAULICALLY-ASSISTED GASKET WITH 2-STAGE SEALING
- LIGHTWEIGHT CONSTRUCTION ENABLES FAST AND EASY INSTALLATION
- ALLOWS 4° DYNAMIC DEFLECTION ON EACH END, REDUCING FUTURE PIPE DAMAGE
- ONE PRODUCT CAN CONNECT PIPES OF TWO DIFFERENT MATERIALS
- AVAILABLE WITH EPDM OR NBR GASKET

SPECIFICATIONS

STANDARDS

HYMAX MEETS OR EXCEEDS STANDARDS NSF 61, NSF 372.

SIZE

AVAILABLE IN NOMINAL DIAMETER FROM 14"-24" STANDARD.
26"-60" MTO (MADE TO ORDER). CALL KRAUSZ FOR DETAILS.

MATERIALS

END RINGS

14"- 16" ASTM A283 / A283M GRADE C STEEL.
(OR DUCTILE IRON CASTING ASTM A536 GRADE 60-40-18).
18"- 60" ASTM A283 / A283M GRADE C STEEL.

CENTER RING

14" - 60" ASTM A283 / A283M GRADE C STEEL.

GASKETS

EPDM AND NBR AVAILABLE. BOTH ARE COMPOUNDED FOR WATER AND SEWAGE,
MEET INTERNATIONAL STANDARDS FOR CONTACT WITH DRINKING WATER.

BRIDGE

AISI 304 STAINLESS STEEL.

SPHERICAL SPACERS

AISI 304 STAINLESS STEEL.

COATING

100% FUSION BONDED EPOXY FOR ENHANCED CORROSION PROTECTION.
NOMINAL THICKNESS 14 MIL.

NUTS AND BOLTS

AISI 304 STAINLESS STEEL. ROLLED THREAD AND ANTI-GALLING COATING.

PROTECTION PARTS CATHODIC

AISI 304 STAINLESS STEEL.

* REGISTERED PATENT

PRODUCT PERFORMANCE (*)

WORKING TEMPERATURE	EPDM: -20°F UP TO +125°F NBR: -4°F UP TO +125°F		
DYNAMIC DEFLECTION	UP TO 4° PER SIDE		
MIN. PIPE INSERTION	14"-60" 4"		
MAXIMUM OFFSET FOR MISALIGNED PIPES	14"-60" 0.51"		
MAXIMUM OUT OF ROUNDNESS	14"-60" 0.51"		
WORKING PRESSURE	14"-16" 260 PSI	18"-24" 232 PSI	26"-60" CALL KRAUSZ FOR DETAILS
RATED PRESSURE	14"-16" 390 PSI	18"-24" 350 PSI	26"-60" CALL KRAUSZ FOR DETAILS
VACUUM TEST	12 PSI		

* SEE SUBMITTAL DRAWINGS FOR DETAILS.

PRODUCT TABLES

PRODUCT CONFIGURATIONS

The product is offered in several different configurations. Note that the "xx" marking in the Cat. no. should be replaced as directed:

Part Number 888-XX

56 -> EPDM gasket

57 -> NBR gasket

For example:

888-XX-0054-16 should be read as 888-56-0054-16 for EPDM gasket and 888-57-0054-16 for NBR gasket.

HYMAX CATHODIC NOMINAL SIZES 14"-24"

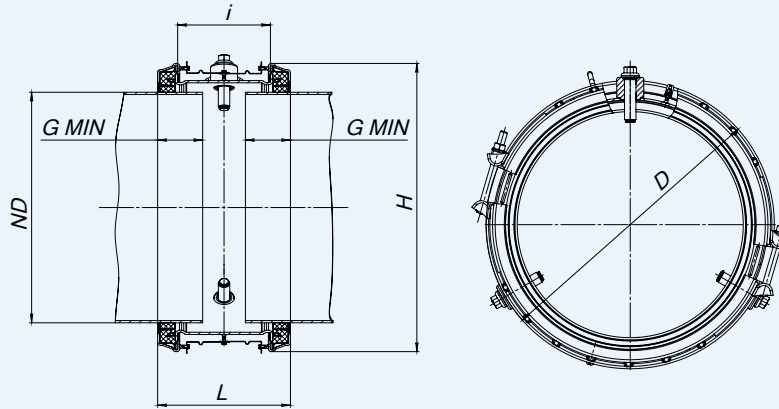

Krausz Part Number	ND (inch)	Overall Range (inch)	Before Removal of Inner Layer (inch)	After Removal of Inner Layer (inch)	D (inch)	H (inch)	i (inch)	L (inch)	Bolts Qty.-Size	Torque (Lt-Lbs)	Approx. Weight (Lbs)
888-56-0378-16P	14"	15.00-17.10	15.00-16.10	16.02-17.10	Ø21.0	23.2	8.0	11.6	4 -M16	150	92
888-56-0434-16P	16"	17.10-19.20	17.10-18.19	18.11-19.20	Ø23.2	25.6	8.0	11.6	4 -M16	150	101
888-56-0488-16P	18"	19.20-21.30	19.20-20.29	20.21-21.30	Ø25.3	27.8	8.0	11.6	4 -M16	150	101
888-56-0497-16P	20"	19.60-21.70	19.60-20.69	20.61-21.70	Ø25.6	28.1	8.0	11.6	4 -M16	150	105
888-56-0540-16P	20"	21.25-23.35	21.25-22.35	22.27-23.35	Ø27.3	29.8	8.0	11.6	4 -M16	150	110
888-56-0606-16P	24"	23.85-25.95	23.85-24.96	24.88-25.95	Ø29.1	31.7	8.0	11.6	4 -M16	150	120
888-56-0624-16P	24"	24.60-26.70	24.60-25.67	25.59-26.70	Ø30.6	33.2	8.0	11.6	4 -M16	150	120

HYMAX CATHODIC NOMINAL SIZES 26"-60"

26"-60" - MTO (MADE TO ORDER) IS AVAILABLE

HYMAX[®]

Repair the past. Connect the future.

 **KRAUSZ** is the creator of HYMAX

331SW 57TH AVENUE, OCALA, FLORIDA 34474

TEL: 855-457-2879 | 855-4KRAUSZ

FAX: 352-304-5787

info@krauszusa.com | www.krauszusa.com

This product is protected under a registered patent. See Krausz USA website for details. Copyright © 2017 Krausz Industries Ltd., All rights reserved