

HYMAX[®]



LARGE DIAMETER COUPLING (HLD) (14"-60")

FEATURES

- GAME-CHANGING WIDE-RANGE COUPLING, PROVEN IN OVER 1M INSTALLATIONS IN THE US
- SUITABLE FOR ALL TYPES OF PIPES - DUCTILE IRON, CAST IRON, STEEL, COPPER, PE, PVC, AC, GRP
- PATENTED HYDRAULICALLY-ASSISTED GASKET WITH 2-STAGE SEALING
- LIGHTWEIGHT CONSTRUCTION ENABLES FAST AND EASY INSTALLATION
- ALLOWS 4° DYNAMIC DEFLECTION ON EACH END, REDUCING FUTURE PIPE DAMAGE
- ONE PRODUCT CAN CONNECT PIPES OF TWO DIFFERENT MATERIALS

SPECIFICATIONS

STANDARDS

HYMAX MEETS OR EXCEEDS STANDARDS AWWA C-219, NSF 61, NSF 372.

SIZE

AVAILABLE IN NOMINAL DIAMETER FROM 14" - 60".
CALL HUMAX FOR DETAILS.

MATERIAL

END RING 14" - 16" ASTM A283 / A283M GRADE C STEEL.
(OR DUCTILE IRON CASTING ASTM A536 GRADE 60-40-18).
18" - 60" ASTM A283 / A283M GRADE C STEEL.

CENTER RING 14" - 60" ASTM A283 / A 283M GRADE C STEEL.

GASKETS COMPOUNDED FOR WATER AND SEWAGE, MEETS INTERNATIONAL STANDARDS FOR CONTACT WITH DRINKING WATER.
14"-24" - AVAILABLE IN EPDM FLIP GASKET.
26"-60" - EPDM ONE-LAYER GASKET.

BRIDGE AISI 304 STAINLESS STEEL.

SPHERICAL SPACERS AISI 304 STAINLESS STEEL.

COATING 100% FUSION BONDED EPOXY FOR ENHANCED CORROSION PROTECTION.
AVERAGE THICKNESS 14 MIL.

NUTS AND BOLTS AISI 304 STAINLESS STEEL. ROLLED THREAD AND ANTI-GALLING COATING.

HYMAX LARGE DIAMETER COUPLING (HLD)



PRODUCT PERFORMANCE

WORKING TEMPERATURE	EPDM: -20°F UP TO +125°F		
DYNAMIC DEFLECTION	UP TO 4° PER SIDE.		
MIN. PIPE INSERTION	14" - 60" 4"		
MAXIMUM OFFSET FOR MISALIGNED PIPES	14" - 60" 0.51"		
MAXIMUM OUT OF ROUNDNESS	14" - 60" 0.51"		
WORKING PRESSURE	1.5" - 16" 260 PSI	18" - 24" 232 PSI	26" - 60" CALL HYMAX FOR DETAILS.
RATED PRESSURE	14" - 16" 390 PSI	18" - 24" 350 PSI	26" - 60" CALL HYMAX FOR DETAILS.
VACUUM TEST	12 PSI		

PRODUCT SPECIFICATIONS

HYMAX LARGE DIAMETER COUPLING (HLD)



PRODUCT TABLES

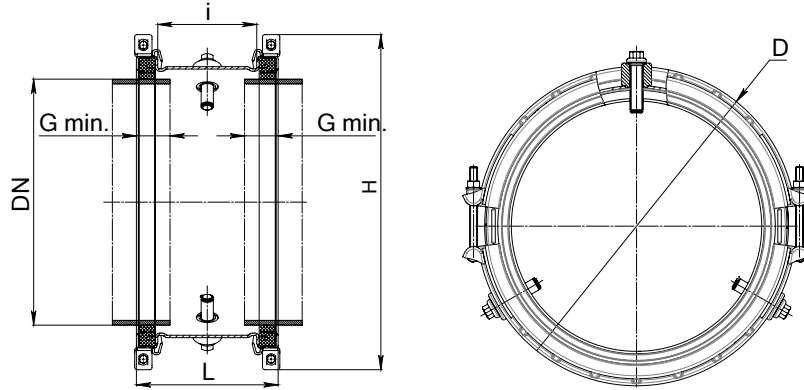

Part Number 860-XX
56 -> Product with EPDM

HYMAX LARGE DIAMETER NOMINAL SIZES 14"-24"

Krausz Part Number	ND (inch)	Overall Range (inch)	Closed gasket position (inch)	Open gasket position (inch)	D (inch)	H (inch)	i (inch)	L (inch)	G-Min Pipe Insert (inch)	Bolts Qty. and Size (mm)	Torque (Ft-Lb)	Working Pressure (PSI)	Rated Pressure (PSI)	Approx. Weight (Lbs)
860-56-0378-16P	14	15.00-17.10	15.00-16.10	16.02-17.10	Ø21.0	23.2	8.0	11.6	4.0	4 -M16	150	260	390	92
860-56-0434-16P	16	17.10-19.20	17.10-18.19	18.11-19.20	Ø23.2	25.6	8.0	11.6	4.0	4 -M16	150	260	390	101
860-56-0488-16P	18	19.20-21.30	19.20-20.29	20.21-21.30	Ø25.3	27.8	8.0	11.6	4.0	4 -M16	150	232	350	101
860-56-0497-16P	20	19.60-21.70	19.60-20.69	20.61-21.70	Ø25.6	28.1	8.0	11.6	4.0	4 -M16	150	232	350	105
860-56-0540-16P	20	21.25-23.35	21.25-22.35	22.27-23.35	Ø27.3	29.8	8.0	11.6	4.0	4 -M16	150	232	350	110
860-56-0606-16P	24	23.85-25.95	23.85-24.96	24.88-25.95	Ø29.1	31.7	8.0	11.6	4.0	4 -M16	150	232	350	120
860-56-0624-16P	24	24.60-26.70	24.60-25.67	25.59-26.70	Ø30.6	33.2	8.0	11.6	4.0	4 -M16	150	232	350	120

HYMAX 26"-60" - MTO (MADE TO ORDER) AVAILABLE
FOR SPECIFIC SIZES OF PRODUCTS IN STOCK, CALL HYMAX FOR DETAILS.

HYMAX[®]

a **MUELLER** brand

331SW 57TH AVENUE, OCALA, FLORIDA 34474

TEL: 855-457-2879 | 855-4KRAUSZ

FAX: 352-304-5787

info@krauszusa.com | www.krauszusa.com

This product is protected under a registered patent. See Krausz website for details. Copyright © 2017 Krausz Industries Ltd., All rights reserved

PS0112 REV A